

SE30P15

**P-Channel Enhancement-Mode MOSFET**

Revision: A

**General Description**

Advanced trench technology to provide excellent RDS(ON), low gate charge and low operation voltage. This device is suitable for using as a load switch or in PWM applications.

- Simple Drive Requirement
- Small Package Outline
- Surface Mount Device

**Features**

For a single MOSFET

- $V_{DS} = -30V$
- $R_{DS(ON)} < 7.5m\Omega @ V_{GS}=-10V$
- $R_{DS(ON)} < 12m\Omega @ V_{GS}=-4.5V$

**Pin configurations**

See Diagram below

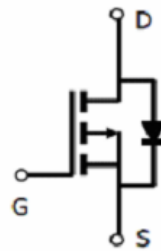
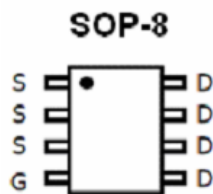

**Absolute Maximum Ratings**

Parameter		Symbol	Rating	Units
Drain-Source Voltage		$V_{DS}$	-30	V
Gate-Source Voltage		$V_{GS}$	$\pm 20$	V
Drain Current	Continuous	$I_D$	-15	A
	Pulsed		-80	
Total Power Dissipation	@TA=25°C	$P_D$	2.1	W
Operating Junction Temperature Range		$T_J$	-55 to 150	°C

## SE30P15

Electrical Characteristics (T <sub>J</sub> =25°C unless otherwise noted)						
Symbol	Parameter	Test Conditions	Min	Typ	Max	Units
<b>OFF CHARACTERISTICS (Note 2)</b>						
BV <sub>DSS</sub>	Drain-Source Breakdown Voltage	I <sub>D</sub> =-250μA, V <sub>GS</sub> =0 V	-30			V
I <sub>DSS</sub>	Drain to Source Leakage Current	V <sub>DS</sub> = -24V, V <sub>GS</sub> =0V			-5	μA
I <sub>GSS</sub>	Gate-Body Leakage Current	V <sub>GS</sub> = 20V			100	nA
V <sub>GS(th)</sub>	Gate Threshold Voltage	V <sub>DS</sub> = V <sub>GS</sub> , I <sub>D</sub> =-250μA	-1.4	-1.9	-2.7	V
R <sub>DS(ON)</sub>	Static Drain-Source On-Resistance <sup>2</sup>	V <sub>GS</sub> =-10V, I <sub>D</sub> =-15A	-	6.2	7.5	mΩ
		V <sub>GS</sub> =-4.5V, I <sub>D</sub> =-10A		9.5	12	mΩ
<b>DYNAMIC PARAMETERS</b>						
C <sub>iss</sub>	Input Capacitance	V <sub>GS</sub> =0V, V <sub>DS</sub> =-15V, f=1MHz		5270		pF
C <sub>oss</sub>	Output Capacitance			945		pF
C <sub>rss</sub>	Reverse Transfer Capacitance			745		pF
<b>SWITCHING PARAMETERS</b>						
Q <sub>g</sub>	Total Gate Charge <sup>2</sup>	V <sub>GS</sub> =-10V, V <sub>DS</sub> =-15V, I <sub>D</sub> =-15A		100		nC
Q <sub>gs</sub>	Gate Source Charge			14.5		nC
Q <sub>gd</sub>	Gate Drain Charge			23		nC
t <sub>d(on)</sub>	Turn-On Delay Time	V <sub>GS</sub> =-10V, V <sub>DS</sub> =-15V, R <sub>GEN</sub> =3Ω, R <sub>L</sub> =1Ω		14		ns
t <sub>d(off)</sub>	Turn-Off Delay Time			76.5		ns
t <sub>d(r)</sub>	Turn-On Rise Time			16.5		ns
t <sub>d(f)</sub>	Turn-Off Fall Time			37.5		ns
<b>Thermal Resistance</b>						
Symbol	Parameter		Typ	Max	Units	
R <sub>θJA</sub>	Junction to Ambient (t ≤ 10s)		26	40	°C/W	

Typical Characteristics

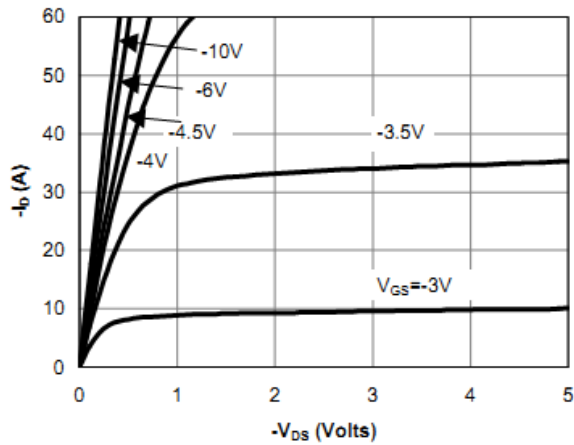

Fig 1: On-Region Characteristics

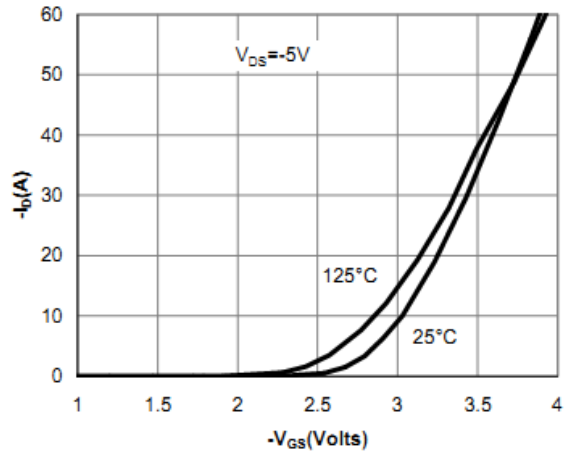

Figure 2: Transfer Characteristics

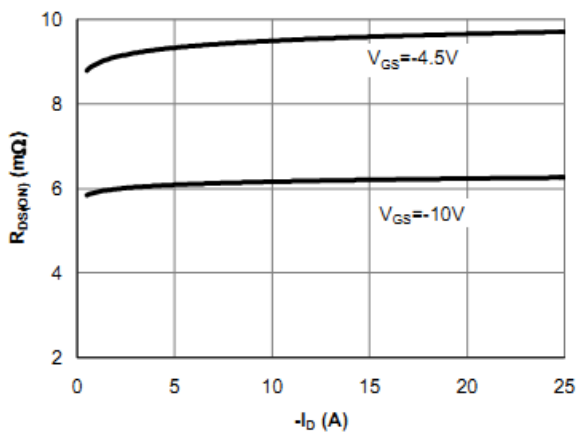

Figure 3: On-Resistance vs. Drain Current and Gate Voltage

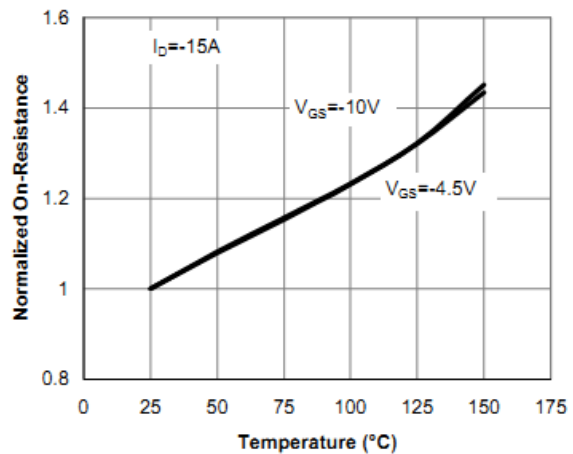

Figure 4: On-Resistance vs. Junction Temperature

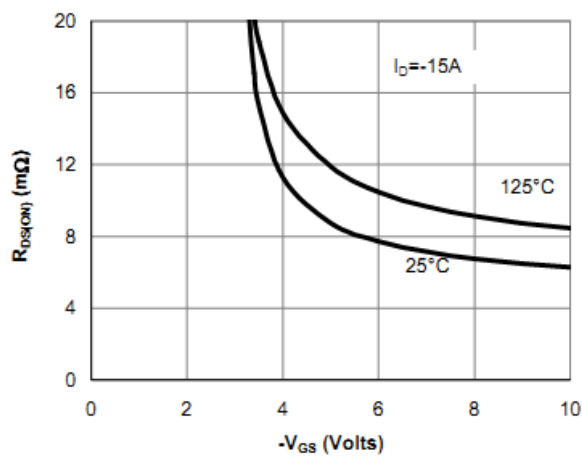

Figure 5: On-Resistance vs. Gate-Source Voltage

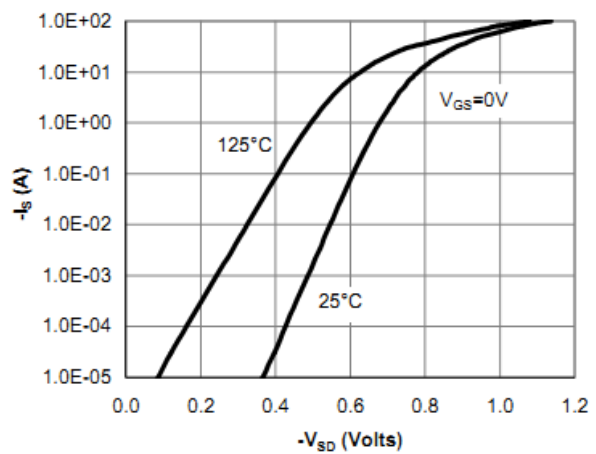

Figure 6: Body-Diode Characteristics

Typical Characteristics

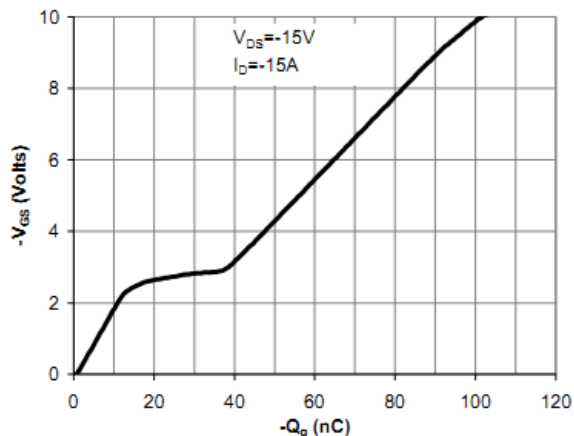

Figure 7: Gate-Charge Characteristics

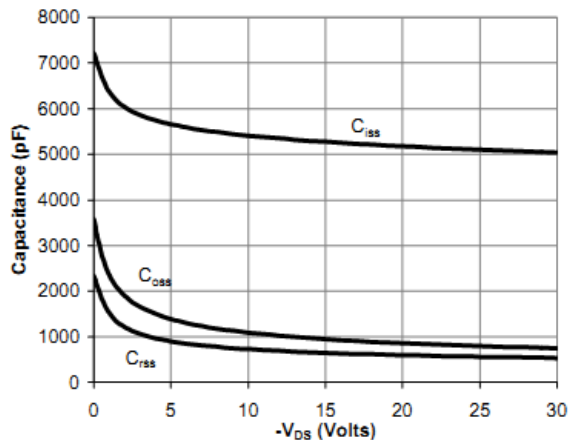

Figure 8: Capacitance Characteristics

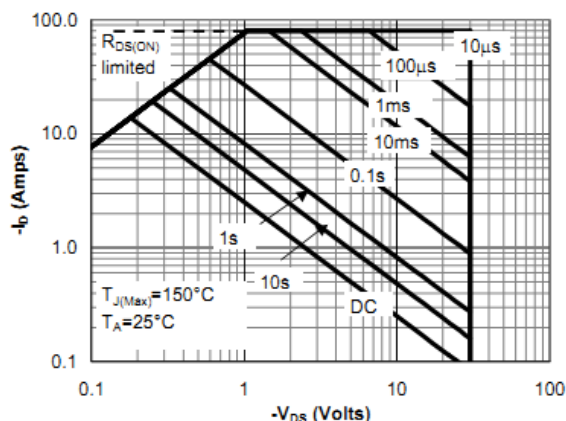

Figure 9: Maximum Forward Biased Safe Operating Area (Note E)

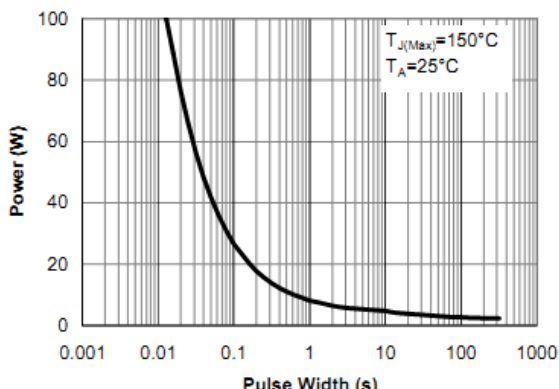

Figure 10: Single Pulse Power Rating Junction-to-Ambient (Note E)

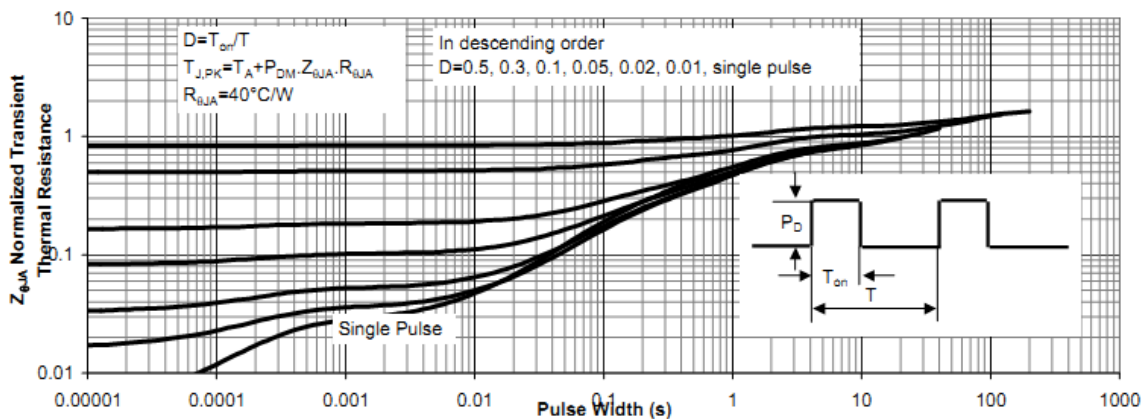
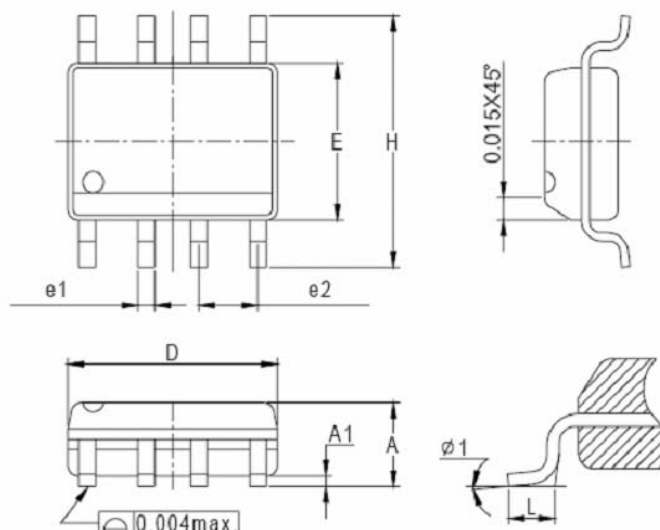

Figure 11: Normalized Maximum Transient Thermal Impedance

# SE30P15

## Package Outline Dimension

### SOP-8



Dim	Millimeters		Inches	
	Min.	Max.	Min.	Max.
A	1.35	1.75	0.053	0.069
A1	0.10	0.25	0.004	0.010
D	4.80	5.00	0.189	0.197
E	3.80	4.00	0.150	0.157
H	5.80	6.20	0.228	0.244
L	0.40	1.27	0.016	0.050
e1	0.33	0.51	0.013	0.020
e2	1.27BSC		0.50BSC	
φ 1	8°		8°	

The SINO-IC logo is a registered trademark of ShangHai Sino-IC Microelectronics Co., Ltd.

© 2005 SINO-IC - Printed in China - All rights reserved.

SHANGHAI SINO-IC MICROELECTRONICS CO., LTD

Add: Building 3, Room 3401-03, No.200 Zhangheng Road,  
ZhangJiang Hi-Tech Park, Pudong, Shanghai 201203, China

Phone: +86-21-33932402 33932403

33932405 33933508 33933608

Fax: +86-21-33932401

Email: [webmaster@sino-ic.com](mailto:webmaster@sino-ic.com)

Website: <http://www.sino-ic.com>